

FP30

Folded Plank 30mm Rainscreen System



Standard Design Details

www.spanwall.com

SPANWALL 

DATE:	ISSUE:	CHANGE:
17/04/2023	Rev A	
12/10/2023	Rev B	Channel / Notes Added

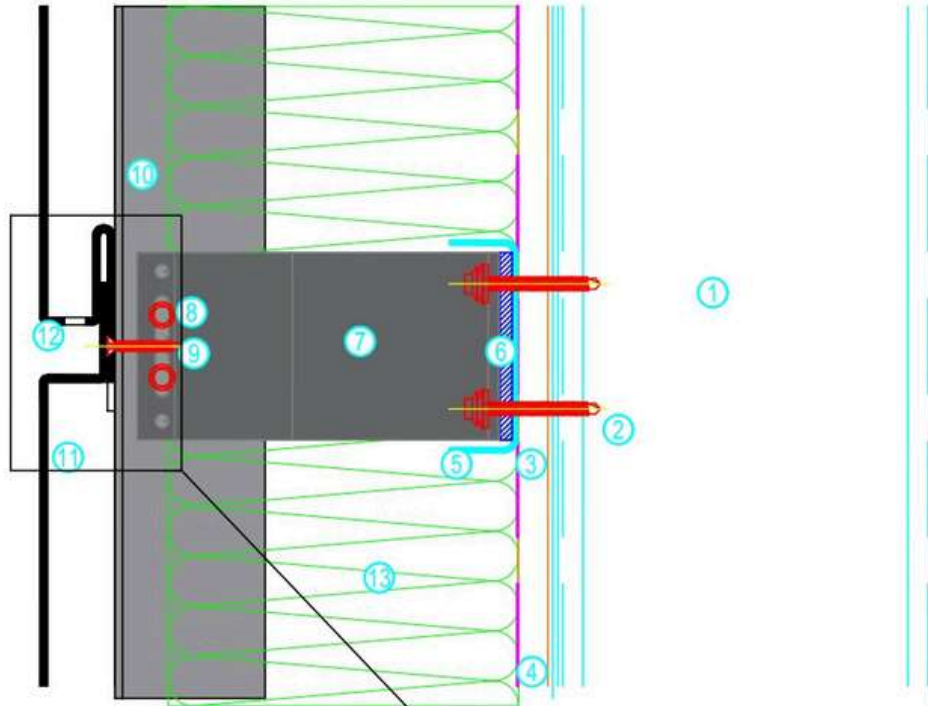

Item	Description
1	Stud Wall (by others)
2	Wall Fixing (by others)
3	Sheathing Board (by others)
4	Vapour Control Layer (by others)
5	Continuous Channel (by others)
6	Thermal Isolator
7	Wall Bracket
8	Mullion Fixing
9	Anti-Lift Fixing
10	Mullion
11	Rainscreen Panel
12	Drainage Hole
13	Insulation (by others)

Note:
Wall construction to be developed and approved to meet deflection, air-tightness, thermal and fire performance requirements.

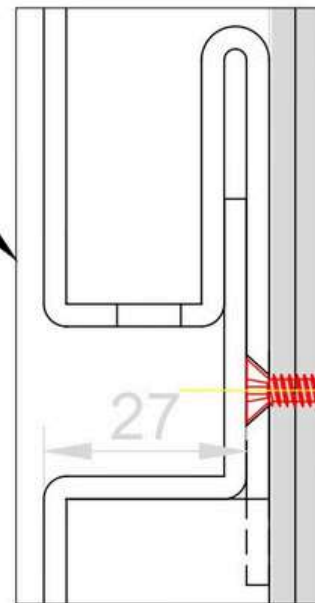

SPANWALL

CARRYDUFF BUSINESS PARK, COMBER ROAD, CARRYDUFF, BELFAST, BT8 8AN.

TEL : +44(0)28 9081 5303 FAX : +44(0)28 9081 5449

E-MAIL : Info@spanwall.com

WEBSITE : www.spanwall.com

TITLE :

Horizontal Joint

DRAWING No. :

Standard Details

DRAWN BY :

Andrew Creane

SCALE :

1:2

PART No. :

FP30-FR-000a

DATE :

17/04/2023

APPROVED BY :

JR

© COPYRIGHT OF THE DESIGNERS.

© DESIGN RIGHTS

DATE:	ISSUE:	CHANGE:
17/04/2023	Rev A	
12/10/2023	Rev B	Channel / Notes Added

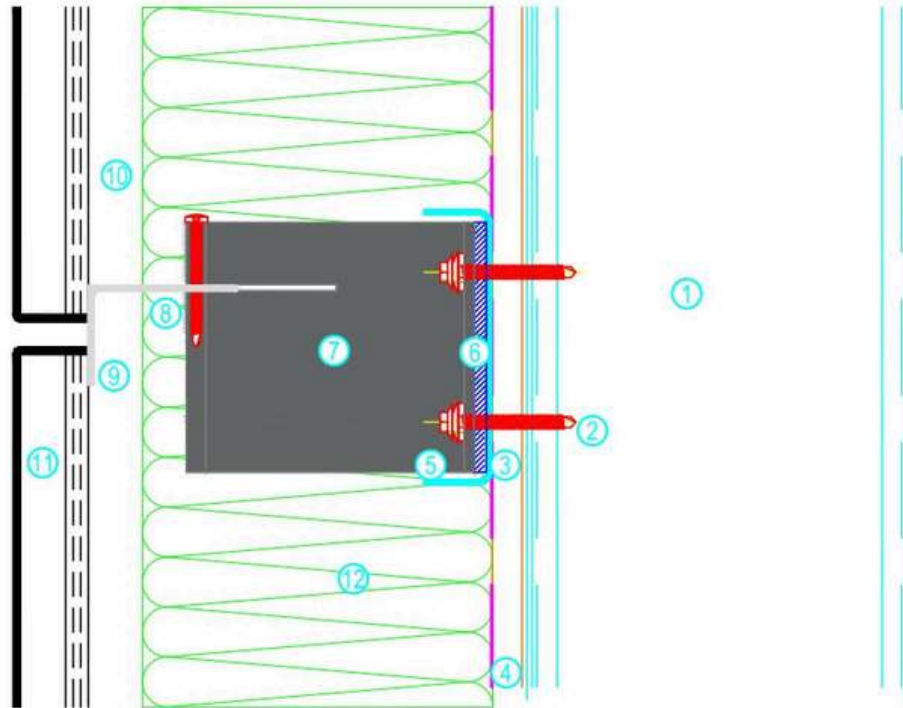

Item	Description
1	Stud Wall (by others)
2	Wall Fixing (by others)
3	Sheathing Board (by others)
4	Vapour Control Layer (by others)
5	Continuous Channel (by others)
6	Thermal Isolator
7	Wall Bracket
8	Rail Fixing
9	Anti-Lift Fixing
10	Rail
11	Rainscreen Panel
12	Insulation (by others)

Note:
Wall construction to be developed and approved to meet deflection, air-tightness, thermal and fire performance requirements.

SPANWALL

CARRYDUFF BUSINESS PARK, COMBER ROAD, CARRYDUFF, BELFAST, BT8 8AN.

TEL : +44(0)28 9081 5303 FAX : +44(0)28 9081 5449

E-MAIL : Info@spanwall.com

WEBSITE : www.spanwall.com

TITLE :

Horizontal Joint

DRAWING No. :

Standard Details

DRAWN BY :

Andrew Creane

SCALE :

1:2

PART No. :

FP30-FR-000b

DATE :

17/04/2023

APPROVED BY :

JR

© COPYRIGHT OF THE DESIGNERS.

DR DESIGN RIGHTS

DATE:	ISSUE:	CHANGE:
17/04/2023	Rev A	
12/10/2023	Rev B	Channel / Notes Added

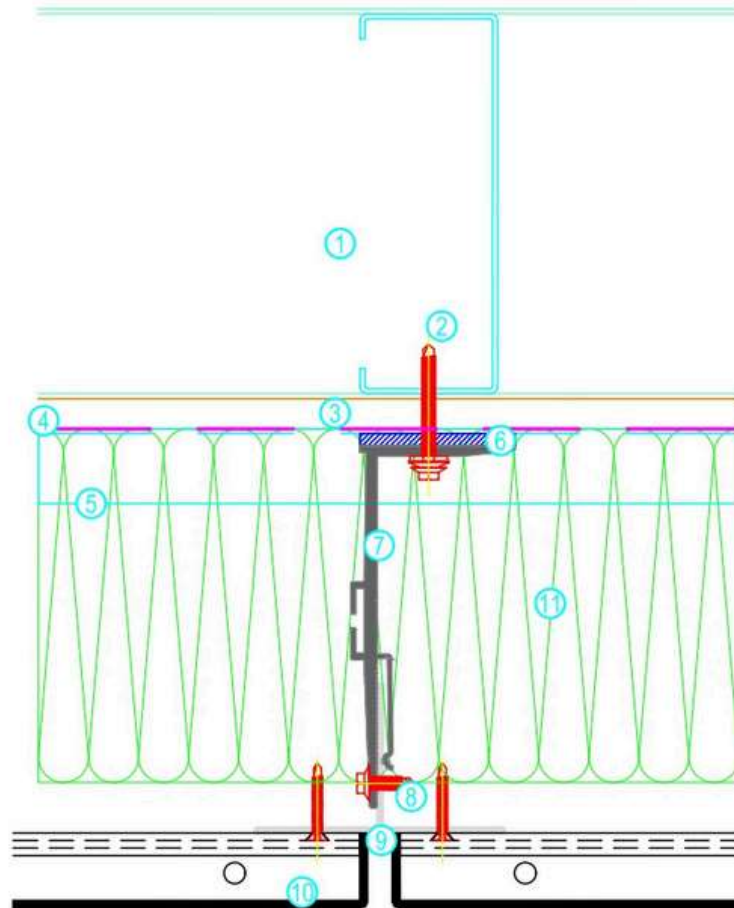

Item	Description
1	Stud Wall (by others)
2	Wall Fixing (by others)
3	Sheathing Board (by others)
4	Vapour Control Layer (by others)
5	Continuous Channel (by others)
6	Thermal Isolator
7	Wall Bracket
8	Mullion Fixing
9	Mullion
10	Rainscreen Panel
11	Insulation (by others)

Note:

Wall construction to be developed and approved to meet deflection, air-tightness, thermal and fire performance requirements.

SPANWALL 

CARRYDUFF BUSINESS PARK, COMBER ROAD, CARRYDUFF, BELFAST, BT8 8AN.

TEL : +44(0)28 9081 5303 FAX : +44(0)28 9081 5449

E-MAIL : Info@spanwall.com

WEBSITE : www.spanwall.com

TITLE :

Vertical Joint

DRAWING No. :

Standard Details

DRAWN BY :

Andrew Creane

SCALE :

1:2

PART No. :

FP30-001a

DATE :

17/04/2023

APPROVED BY :

JR

© COPYRIGHT OF THE DESIGNERS.

© DESIGN RIGHTS

DATE:	ISSUE:	CHANGE:
17/04/2023	Rev A	
12/10/2023	Rev B	Channel / Notes Added

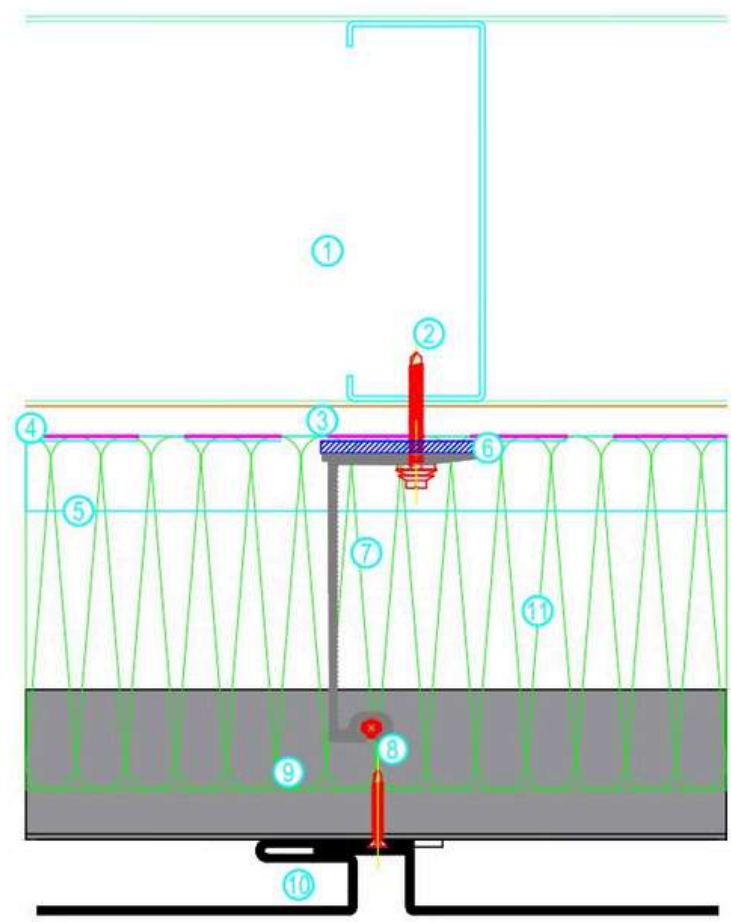

Item	Description
1	Stud Wall (by others)
2	Wall Fixing (by others)
3	Sheathing Board (by others)
4	Vapour Control Layer (by others)
5	Continuous Channel (by others)
6	Thermal Isolator
7	Wall Bracket
8	Rail Fixing
9	Rail
10	Rainscreen Panel
11	Insulation (by others)

Note:
 Wall construction to be developed and approved to meet deflection, air-tightness, thermal and fire performance requirements.

SPANWALL

CARRYDUFF BUSINESS PARK, COMBER ROAD, CARRYDUFF, BELFAST, BT8 8AN.
 TEL : +44(0)28 9081 5303 FAX : +44(0)28 9081 5449
 E-MAIL : Info@spanwall.com
 WEBSITE : www.spanwall.com

TITLE :		Vertical Joint	
DRAWING No. :	Standard Details	DRAWN BY :	Andrew Creane
PART No. :	FP30-001b	DATE :	17/04/2023
		SCALE :	1:2
		APPROVED BY :	JR
© COPYRIGHT OF THE DESIGNERS.		© DESIGN RIGHTS	

DATE:	ISSUE:	CHANGE:
19/04/2023	Rev A	
12/10/2023	Rev B	Channel / Notes Added

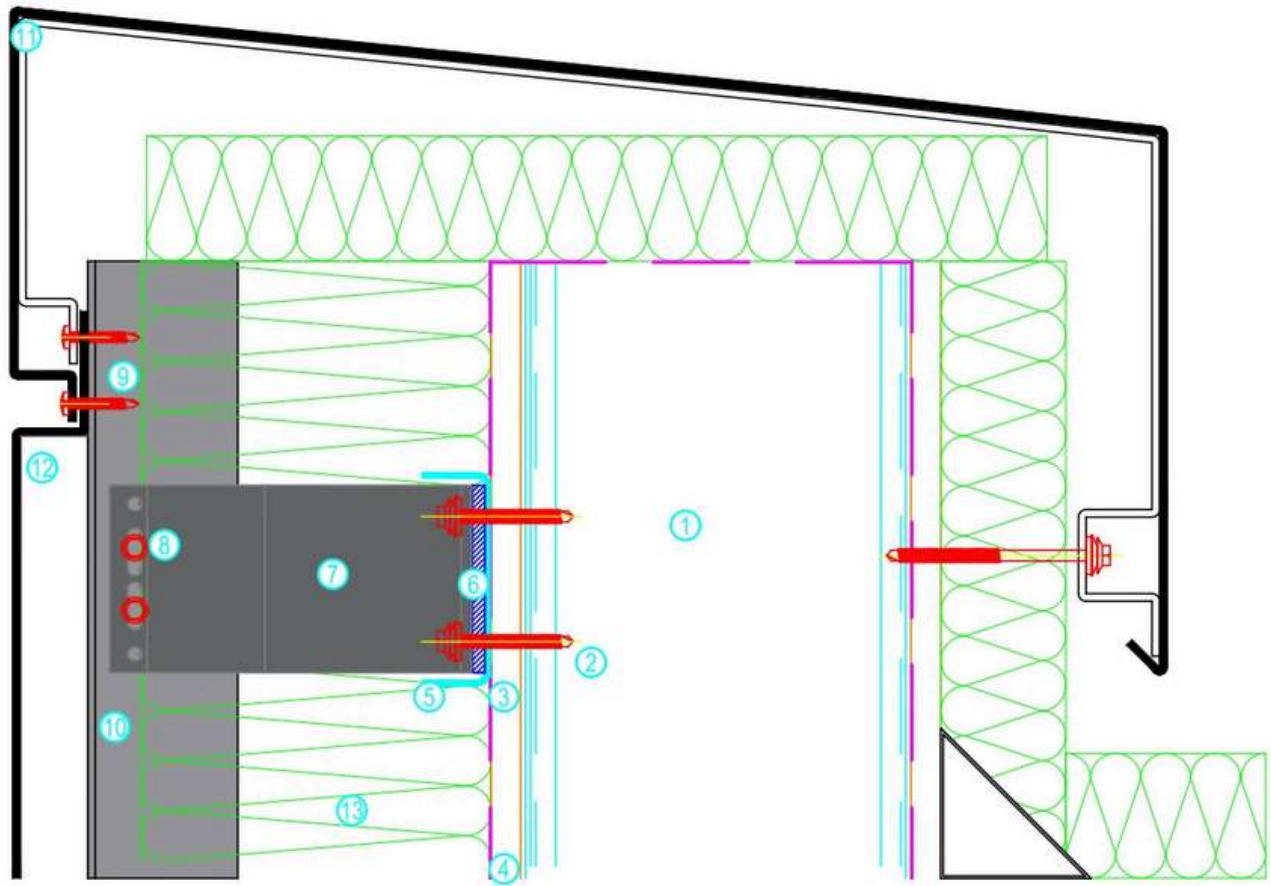

Item	Description
1	Stud Wall (by others)
2	Wall Fixing (by others)
3	Sheathing Board (by others)
4	Vapour Control Layer (by others)
5	Continuous Channel (by others)
6	Thermal Isolator
7	Wall Bracket
8	Mullion Fixing
9	Anti-Lift Fixing
10	Mullion
11	Coping Panel (Typical)
12	Rainscreen Panel
13	Insulation (by others)

Note:
Wall construction to be developed and approved to meet deflection, air-tightness, thermal and fire performance requirements.

SPANWALL 

CARRYDUFF BUSINESS PARK, COMBER ROAD, CARRYDUFF, BELFAST, BT8 8AN.
 TEL : +44(0)28 9081 5303 FAX : +44(0)28 9081 5449
 E-MAIL : Info@spanwall.com
 WEBSITE : www.spanwall.com

TITLE :		Coping Detail	
DRAWING No. :	Standard Details	DRAWN BY :	Andrew Creane
PART No. :	FP30-002a	DATE :	19/04/2023
		SCALE :	1:3
		APPROVED BY :	JR
© COPYRIGHT OF THE DESIGNERS.		© DESIGN RIGHTS	

DATE:	ISSUE:	CHANGE:
12/10/2023	Rev A	

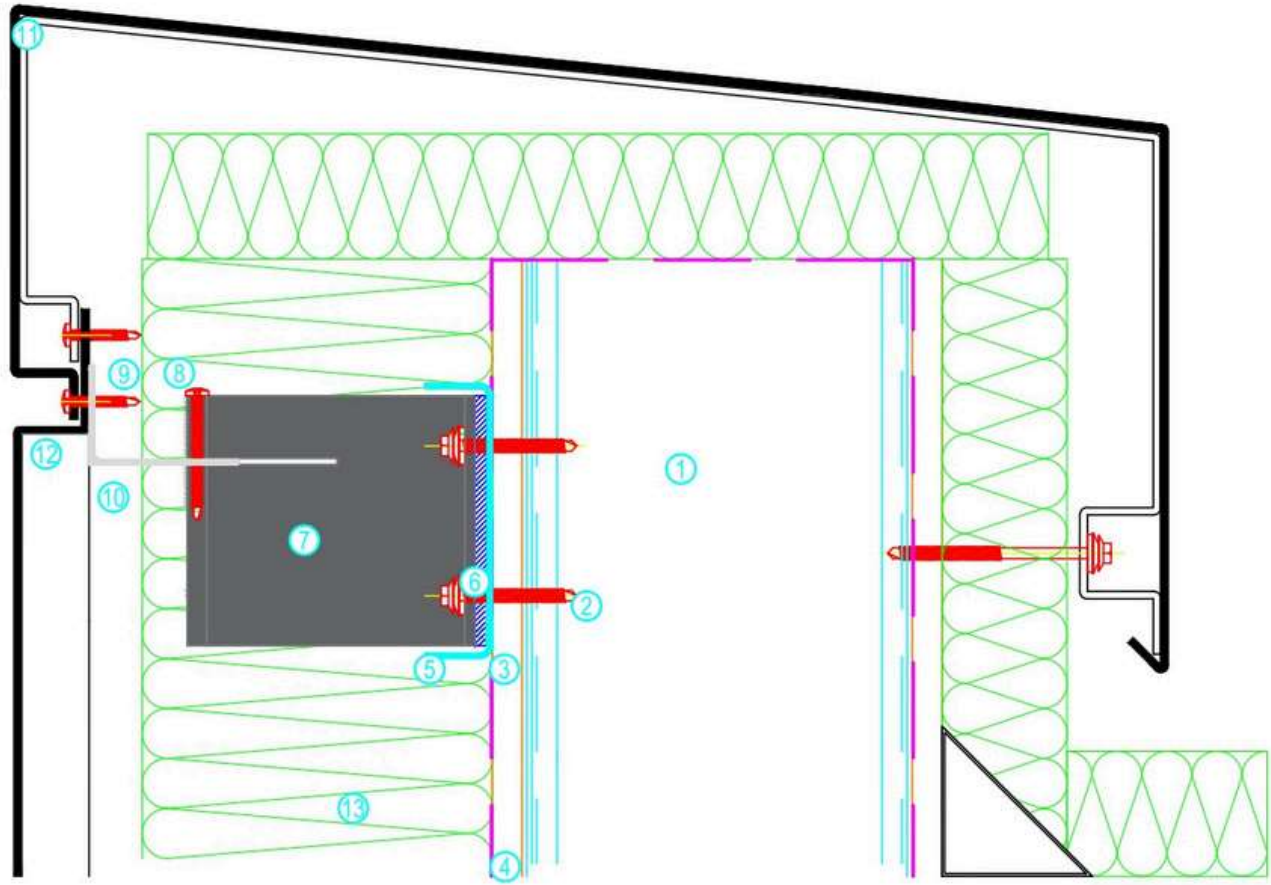

Item	Description
1	Stud Wall (by others)
2	Wall Fixing (by others)
3	Sheathing Board (by others)
4	Vapour Control Layer (by others)
5	Continuous Channel (by others)
6	Thermal Isolator
7	Wall Bracket
8	Rail Fixing
9	Anti-Lift Fixing
10	Rail
11	Coping Panel (Typical)
12	Rainscreen Panel
13	Insulation (by others)

Note:
 Wall construction to be developed and approved to meet deflection, air-tightness, thermal and fire performance requirements.

SPANWALL 

CARRYDUFF BUSINESS PARK, COMBER ROAD, CARRYDUFF, BELFAST, BT8 8AN.
 TEL : +44(0)28 9081 5303 FAX : +44(0)28 9081 5449
 E-MAIL : Info@spanwall.com
 WEBSITE : www.spanwall.com

TITLE :		Coping Detail	
DRAWING No. :	Standard Details	DRAWN BY :	Andrew Creane
PART No. :	FP30-002b	DATE :	12/10/2023
		SCALE :	1:3
		APPROVED BY :	JR
© COPYRIGHT OF THE DESIGNERS.		© DESIGN RIGHTS	

DATE:	ISSUE:	CHANGE:
19/04/2023	Rev A	
12/10/2023	Rev B	Channel / Notes Added

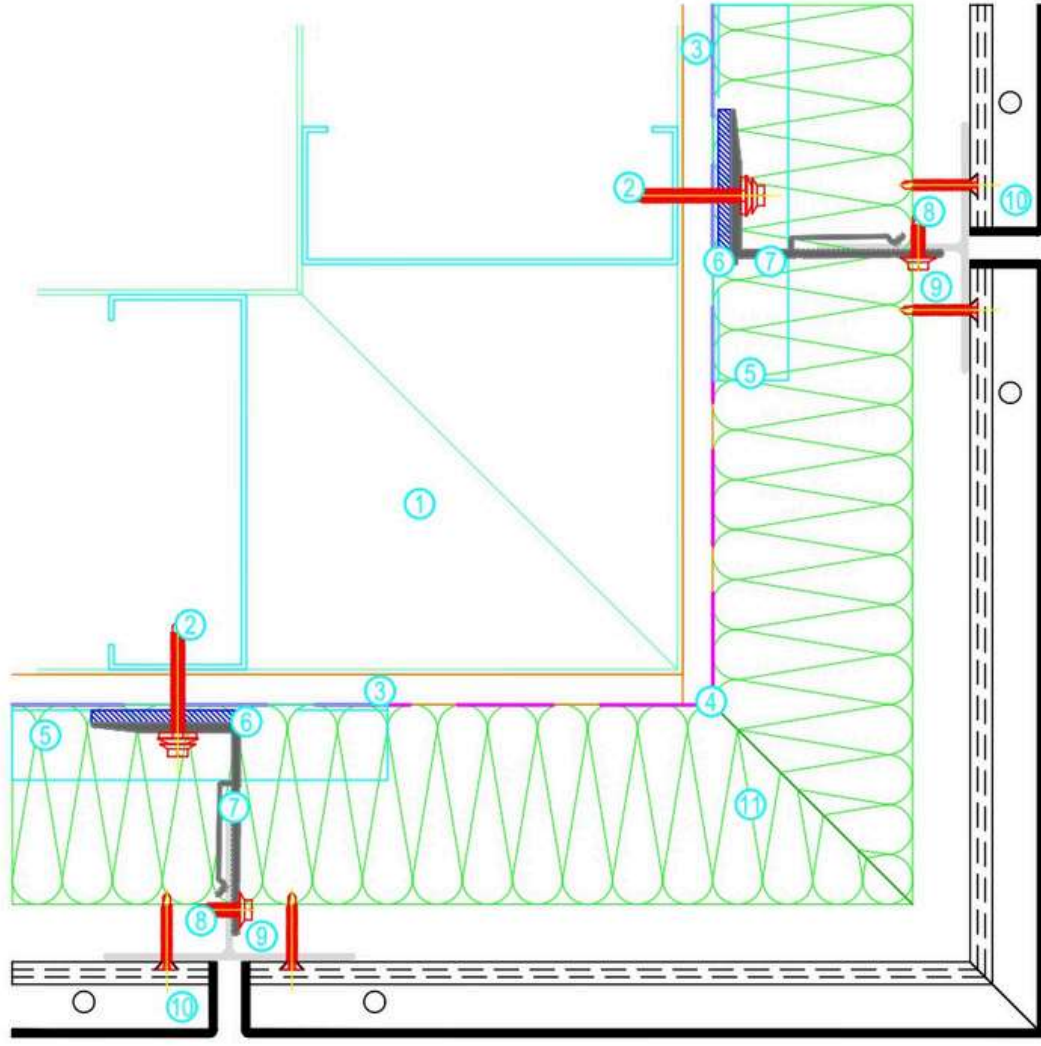

Item	Description
1	Stud Wall (by others)
2	Wall Fixing (by others)
3	Sheathing Board (by others)
4	Vapour Control Layer (by others)
5	Continuous Channel (by others)
6	Thermal Isolator
7	Wall Bracket
8	Mullion Fixing
9	Mullion
10	Rainscreen Panel
11	Insulation (by others)

Note:
 Wall construction to be developed and approved to meet deflection, air-tightness, thermal and fire performance requirements.

SPANWALL

CARRYDUFF BUSINESS PARK, COMBER ROAD, CARRYDUFF, BELFAST, BT8 8AN.
 TEL : +44(0)28 9081 5303 FAX : +44(0)28 9081 5449
 E-MAIL : Info@spanwall.com
 WEBSITE : www.spanwall.com

TITLE :		External Corner Detail	
DRAWING No. :	Standard Details	DRAWN BY :	Andrew Creane
PART No. :	FP30-003a	DATE :	19/04/2023
		SCALE :	1:3
		APPROVED BY :	JR
© COPYRIGHT OF THE DESIGNERS.		DP DESIGN RIGHTS	

DATE:	ISSUE:	CHANGE:
19/04/2023	Rev A	
12/10/2023	Rev B	Channel / Notes Added

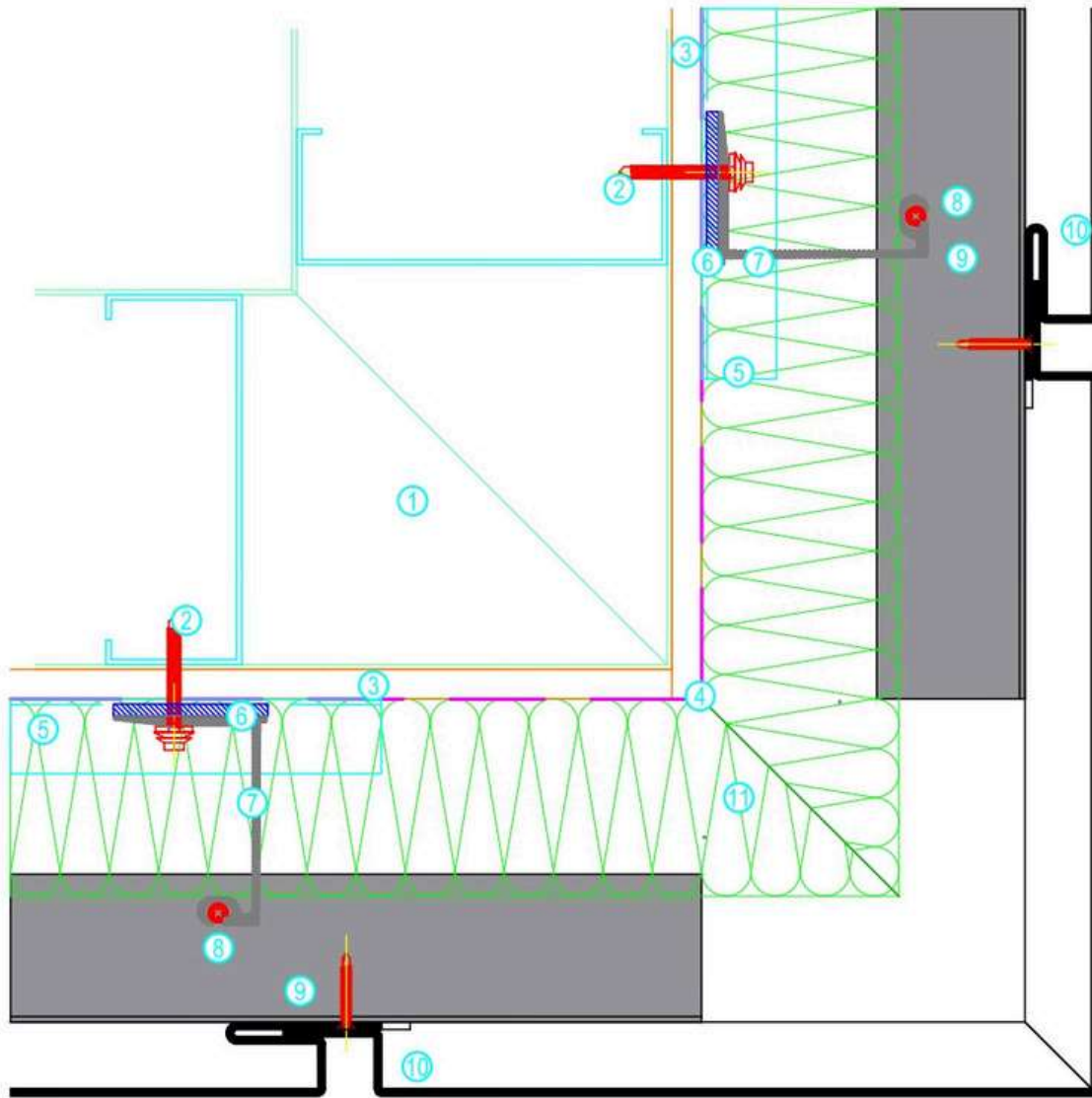

Item	Description
1	Stud Wall (by others)
2	Wall Fixing (by others)
3	Sheathing Board (by others)
4	Vapour Control Layer (by others)
5	Continuous Channel (by others)
6	Thermal Isolator
7	Wall Bracket
8	Rail Fixing
9	Rail
10	Rainscreen Panel
11	Insulation (by others)

Note:
 Wall construction to be developed and approved to meet deflection, air-tightness, thermal and fire performance requirements.

SPANWALL

CARRYDUFF BUSINESS PARK, COMBER ROAD, CARRYDUFF, BELFAST, BT8 8AN.

TEL : +44(0)28 9081 5303 FAX : +44(0)28 9081 5449

E-MAIL : Info@spanwall.com

WEBSITE : www.spanwall.com

TITLE :

External Corner Detail

DRAWING No. :

Standard Details

DRAWN BY :

Andrew Creane

SCALE :

1:3

PART No. :

FP30-003

DATE :

19/04/2023

APPROVED BY :

JR

© COPYRIGHT OF THE DESIGNERS.

DP DESIGN RIGHTS

DATE:	ISSUE:	CHANGE:
20/04/2023	Rev A	
12/10/2023	Rev B	Channel / Notes Added

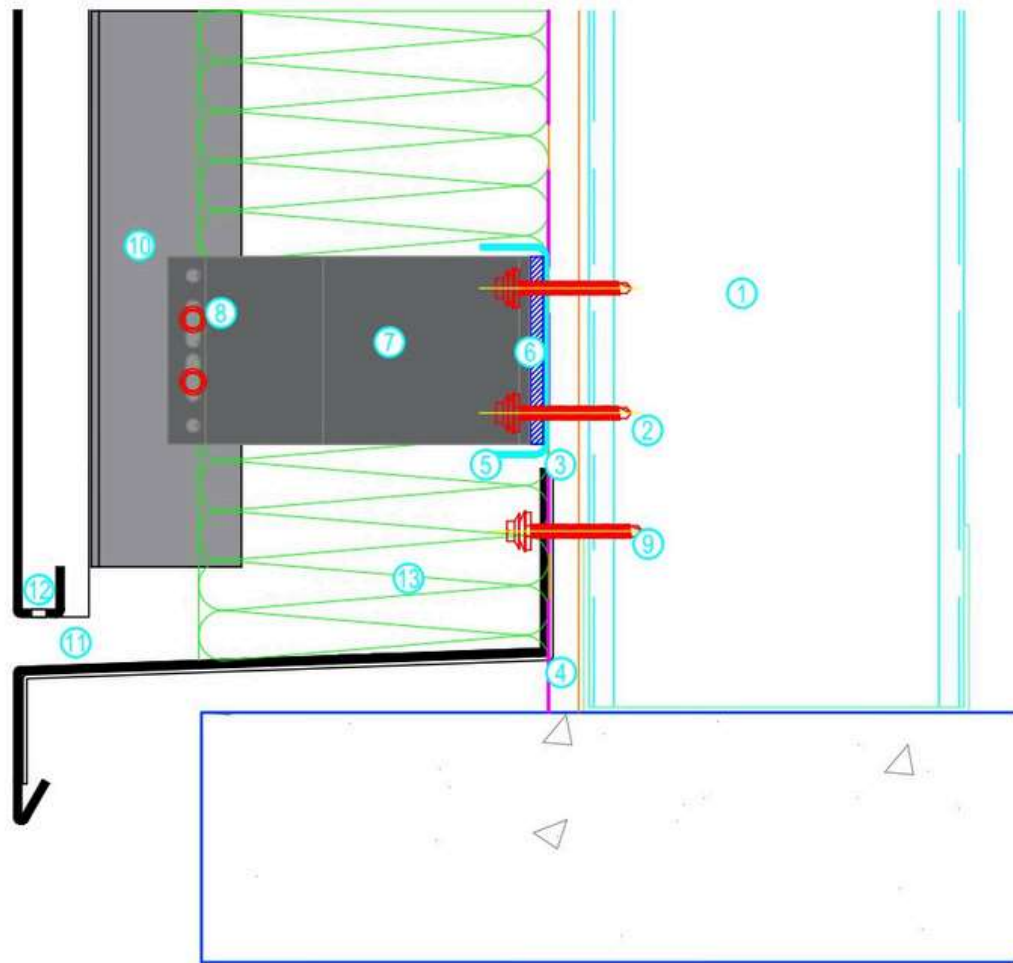

Item	Description
1	Stud Wall (by others)
2	Wall Fixing (by others)
3	Sheathing Board (by others)
4	Vapour Control Layer (by others)
5	Continuous Channel (by others)
6	Thermal Isolator
7	Wall Bracket
8	Mullion Fixing
9	Cill Fixing
10	Mullion
11	Bottom Cill
12	Rainscreen Panel
13	Insulation (by others)

Note:
Wall construction to be developed and approved to meet deflection, air-tightness, thermal and fire performance requirements.

SPANWALL

CARRYDUFF BUSINESS PARK, COMBER ROAD, CARRYDUFF, BELFAST, BT8 8AN.

TEL : +44(0)28 9081 5303 FAX : +44(0)28 9081 5449

E-MAIL : Info@spanwall.com

WEBSITE : www.spanwall.com

TITLE :

Bottom Cill

DRAWING No. :

Standard Details

DRAWN BY :

Andrew Creane

SCALE :

1:2

PART No. :

FP30-004a

DATE :

20/04/2023

APPROVED BY :

JR

© COPYRIGHT OF THE DESIGNERS.

© DESIGN RIGHTS

DATE:	ISSUE:	CHANGE:
12/10/2023	Rev A	

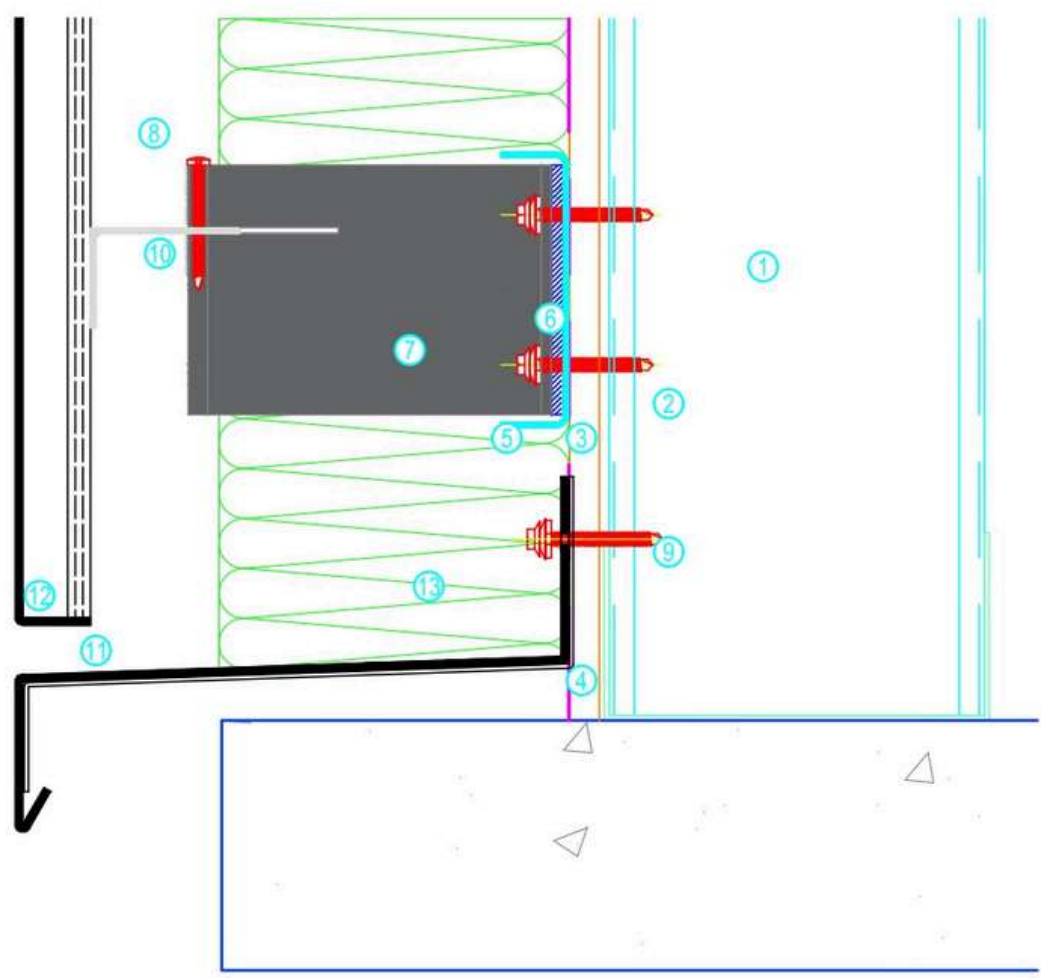

Item	Description
1	Stud Wall (by others)
2	Wall Fixing (by others)
3	Sheathing Board (by others)
4	Vapour Control Layer (by others)
5	Continuous Channel (by others)
6	Thermal Isolator
7	Wall Bracket
8	Rail Fixing
9	Cill Fixing
10	Rail
11	Bottom Cill
12	Rainscreen Panel
13	Insulation (by others)

Note:
 Wall construction to be developed and approved to meet deflection, air-tightness, thermal and fire performance requirements.

SPANWALL 

CARRYDUFF BUSINESS PARK, COMBER ROAD, CARRYDUFF, BELFAST, BT8 8AN.
 TEL : +44(0)28 9081 5303 FAX : +44(0)28 9081 5449
 E-MAIL : Info@spanwall.com
 WEBSITE : www.spanwall.com

TITLE :		Bottom Cill	
DRAWING No. :	Standard Details	DRAWN BY :	Andrew Creane
PART No. :	FP30-004b	DATE :	12/10/2023
		SCALE :	1:2
		APPROVED BY :	JR
© COPYRIGHT OF THE DESIGNERS.		© DESIGN RIGHTS	

DATE:	ISSUE:	CHANGE:
20/04/2023	Rev A	
12/10/2023	Rev B	Channel / Notes Added

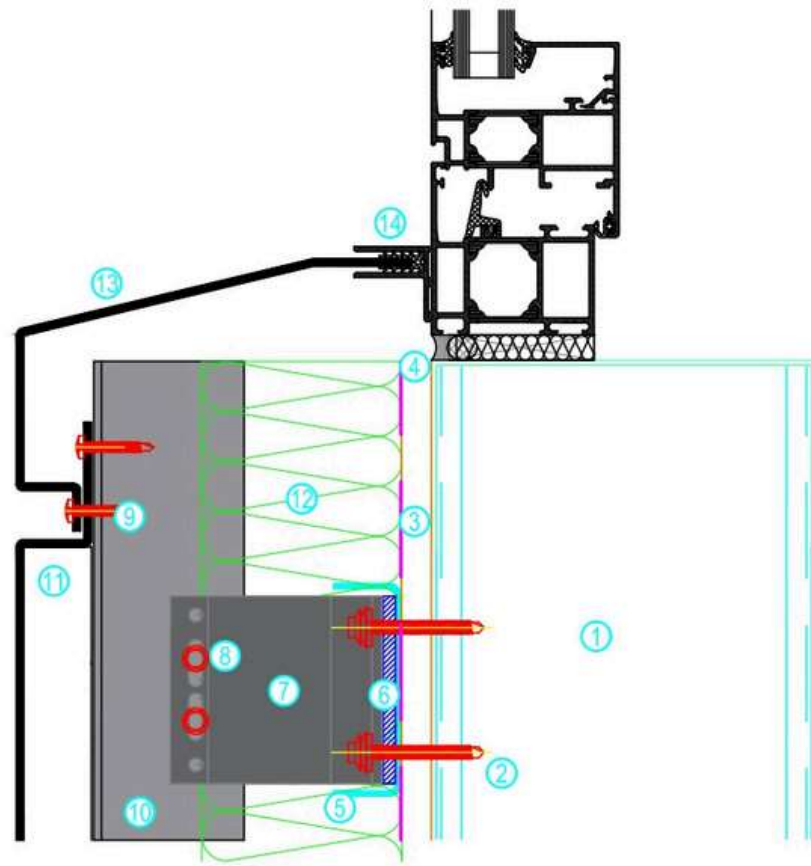

Item	Description
1	Stud Wall (by others)
2	Wall Fixing (by others)
3	Sheathing Board (by others)
4	Vapour Control Layer (by others)
5	Continuous Channel (by others)
6	Thermal Isolator
7	Wall Bracket
8	Mullion Fixing
9	Anti-Lift Fixing
10	Mullion
11	Rainscreen Panel
12	Insulation (by others)
13	Window Cill Flashing
14	F-Section

Note:
Wall construction to be developed and approved to meet deflection, air-tightness, thermal and fire performance requirements.

SPANWALL

CARRYDUFF BUSINESS PARK, COMBER ROAD, CARRYDUFF, BELFAST, BT8 8AN.
 TEL : +44(0)28 9081 5303 FAX : +44(0)28 9081 5449
 E-MAIL : Info@spanwall.com
 WEBSITE : www.spanwall.com

TITLE :		Window Cill	
DRAWING No. :	Standard Details	DRAWN BY :	Andrew Creane
PART No. :	FP30-005a	DATE :	20/04/2023
		SCALE :	1:2
		APPROVED BY :	JR
© COPYRIGHT OF THE DESIGNERS.		DESIGN RIGHTS	

DATE:	ISSUE:	CHANGE:
12/10/2023	Rev A	

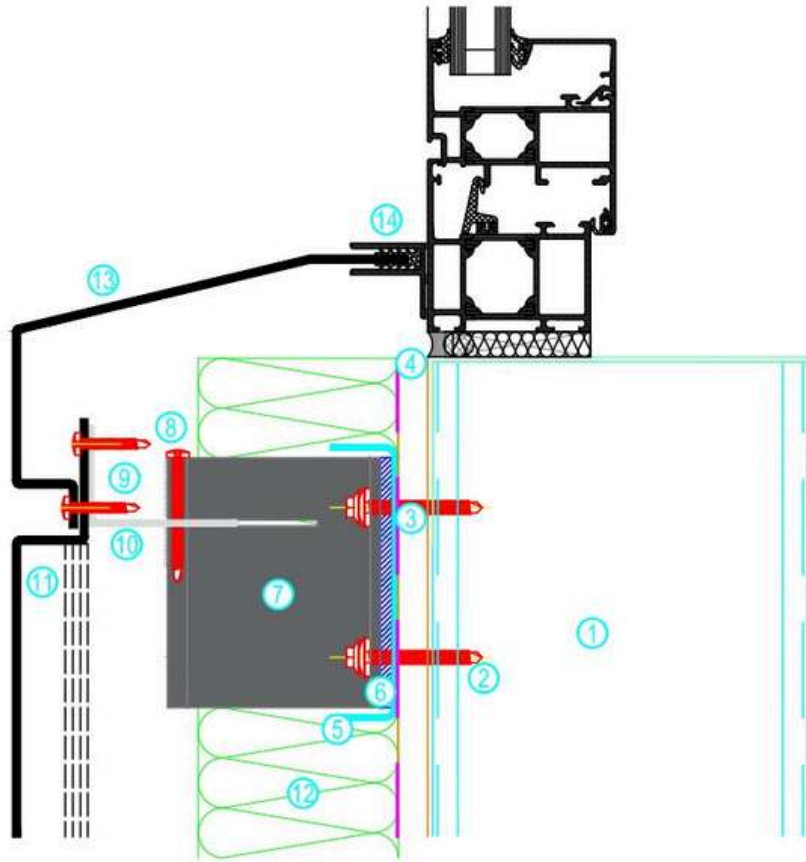

Item	Description
1	Stud Wall (by others)
2	Wall Fixing (by others)
3	Sheathing Board (by others)
4	Vapour Control Layer (by others)
5	Continuous Channel (by others)
6	Thermal Isolator
7	Wall Bracket
8	Rail Fixing
9	Anti-Lift Fixing
10	Rail
11	Rainscreen Panel
12	Insulation (by others)
13	Window Cill Flashing
14	F-Section

Note:
Wall construction to be developed and approved to meet deflection, air-tightness, thermal and fire performance requirements.

SPANWALL

CARRYDUFF BUSINESS PARK, COMBER ROAD, CARRYDUFF, BELFAST, BT8 8AN.

TEL : +44(0)28 9081 5303 FAX : +44(0)28 9081 5449

E-MAIL : Info@spanwall.com

WEBSITE : www.spanwall.com

TITLE :

Window Cill

DRAWING No. :

Standard Details

DRAWN BY :

Andrew Creane

SCALE :

1:2

PART No. :

FP30-005b

DATE :

20/04/2023

APPROVED BY :

JR

© COPYRIGHT OF THE DESIGNERS.

© DESIGN RIGHTS

DATE:	ISSUE:	CHANGE:
20/04/2023	Rev A	
12/10/2023	Rev B	Channel / Notes Added

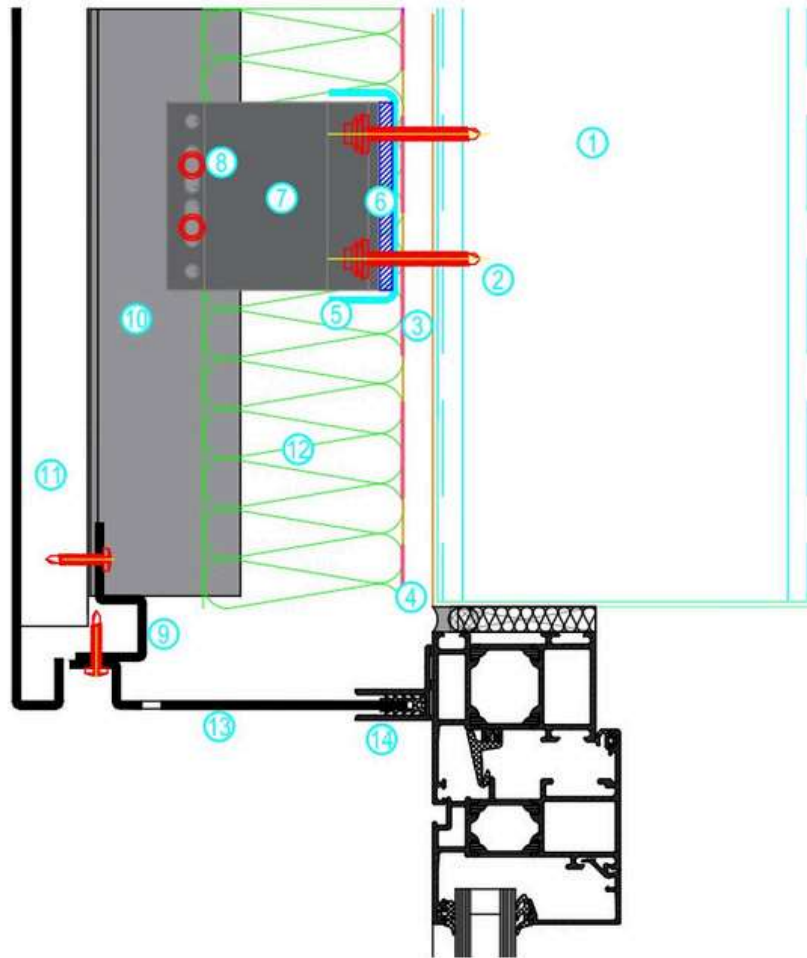

Item	Description
1	Stud Wall (by others)
2	Wall Fixing (by others)
3	Sheathing Board (by others)
4	Vapour Control Layer (by others)
5	Continuous Channel (by others)
6	Thermal Isolator
7	Wall Bracket
8	Mullion Fixing
9	Support Angle
10	Mullion
11	Rainscreen Panel
12	Insulation (by others)
13	Head Flashing
14	F-Section

Note:

Wall construction to be developed and approved to meet deflection, air-tightness, thermal and fire performance requirements.

SPANWALL

CARRYDUFF BUSINESS PARK, COMBER ROAD, CARRYDUFF, BELFAST, BT8 8AN.

TEL : +44(0)28 9081 5303 FAX : +44(0)28 9081 5449

E-MAIL : Info@spanwall.com

WEBSITE : www.spanwall.com

TITLE :

Window Head

DRAWING No. :

Standard Details

DRAWN BY :

Andrew Creane

SCALE :

1:2

PART No. :

FP30-006a

DATE :

20/04/2023

APPROVED BY :

JR

© COPYRIGHT OF THE DESIGNERS.

© DESIGN RIGHTS

DATE:	ISSUE:	CHANGE:
21/04/2023	Rev A	
12/10/2023	Rev B	Cladding Zones Adjusted

(L)GEM1
 * - Maximum panel position to inside
 ** - Maximum panel position to outside
 SPP - Standard panel position

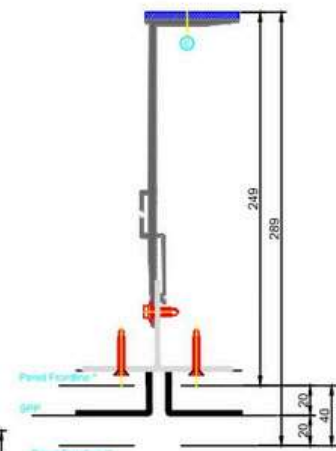
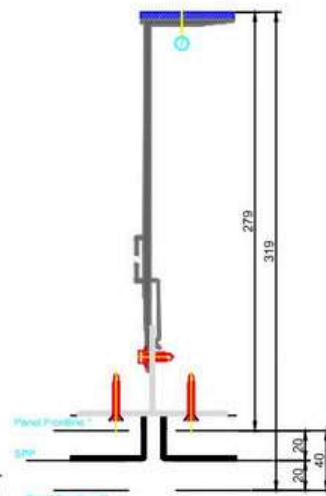
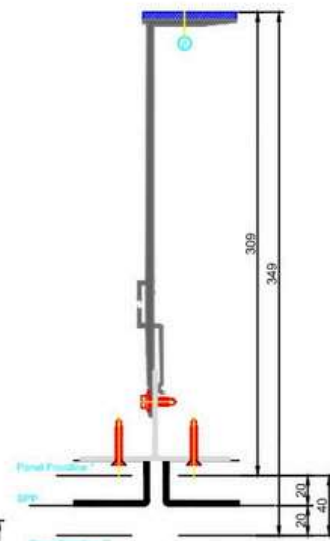
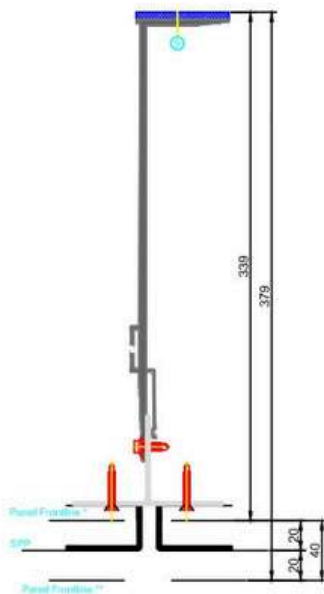
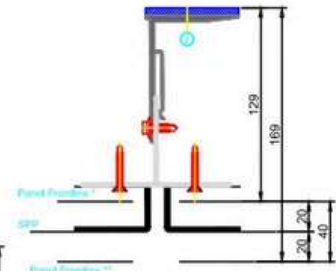
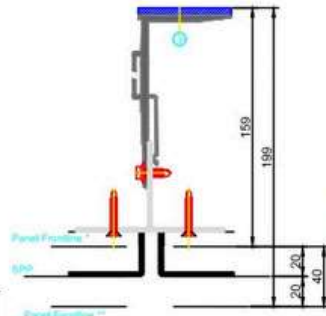
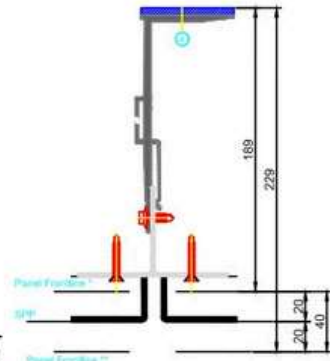
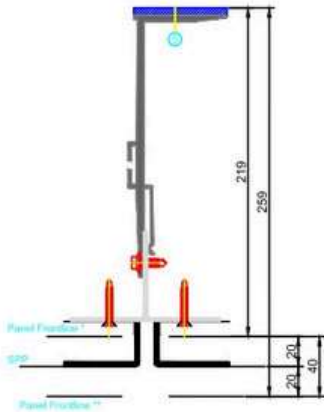
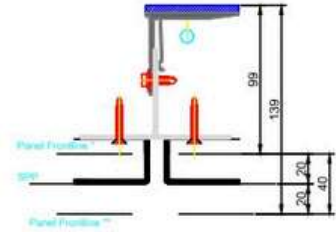
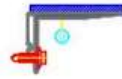

Panel Description	Cladding Zone Range
FP30 Standard 000	FP30 Standard
FP30 Standard 001	FP30 Standard
FP30 Standard 002	FP30 Standard
FP30 Standard 003	FP30 Standard
FP30 Standard 004	FP30 Standard
FP30 Standard 005	FP30 Standard
FP30 Standard 006	FP30 Standard
FP30 Standard 007	FP30 Standard
FP30 Standard 008	FP30 Standard
FP30 Standard 009	FP30 Standard
FP30 Standard 010	FP30 Standard
FP30 Standard 011	FP30 Standard
FP30 Standard 012	FP30 Standard
FP30 Standard 013	FP30 Standard
FP30 Standard 014	FP30 Standard
FP30 Standard 015	FP30 Standard
FP30 Standard 016	FP30 Standard
FP30 Standard 017	FP30 Standard
FP30 Standard 018	FP30 Standard
FP30 Standard 019	FP30 Standard
FP30 Standard 020	FP30 Standard
FP30 Standard 021	FP30 Standard
FP30 Standard 022	FP30 Standard
FP30 Standard 023	FP30 Standard
FP30 Standard 024	FP30 Standard
FP30 Standard 025	FP30 Standard
FP30 Standard 026	FP30 Standard
FP30 Standard 027	FP30 Standard
FP30 Standard 028	FP30 Standard
FP30 Standard 029	FP30 Standard
FP30 Standard 030	FP30 Standard
FP30 Standard 031	FP30 Standard
FP30 Standard 032	FP30 Standard
FP30 Standard 033	FP30 Standard
FP30 Standard 034	FP30 Standard
FP30 Standard 035	FP30 Standard
FP30 Standard 036	FP30 Standard
FP30 Standard 037	FP30 Standard
FP30 Standard 038	FP30 Standard
FP30 Standard 039	FP30 Standard
FP30 Standard 040	FP30 Standard
FP30 Standard 041	FP30 Standard
FP30 Standard 042	FP30 Standard
FP30 Standard 043	FP30 Standard
FP30 Standard 044	FP30 Standard
FP30 Standard 045	FP30 Standard
FP30 Standard 046	FP30 Standard
FP30 Standard 047	FP30 Standard
FP30 Standard 048	FP30 Standard
FP30 Standard 049	FP30 Standard
FP30 Standard 050	FP30 Standard
FP30 Standard 051	FP30 Standard
FP30 Standard 052	FP30 Standard
FP30 Standard 053	FP30 Standard
FP30 Standard 054	FP30 Standard
FP30 Standard 055	FP30 Standard
FP30 Standard 056	FP30 Standard
FP30 Standard 057	FP30 Standard
FP30 Standard 058	FP30 Standard
FP30 Standard 059	FP30 Standard
FP30 Standard 060	FP30 Standard
FP30 Standard 061	FP30 Standard
FP30 Standard 062	FP30 Standard
FP30 Standard 063	FP30 Standard
FP30 Standard 064	FP30 Standard
FP30 Standard 065	FP30 Standard
FP30 Standard 066	FP30 Standard
FP30 Standard 067	FP30 Standard
FP30 Standard 068	FP30 Standard
FP30 Standard 069	FP30 Standard
FP30 Standard 070	FP30 Standard
FP30 Standard 071	FP30 Standard
FP30 Standard 072	FP30 Standard
FP30 Standard 073	FP30 Standard
FP30 Standard 074	FP30 Standard
FP30 Standard 075	FP30 Standard
FP30 Standard 076	FP30 Standard
FP30 Standard 077	FP30 Standard
FP30 Standard 078	FP30 Standard
FP30 Standard 079	FP30 Standard
FP30 Standard 080	FP30 Standard
FP30 Standard 081	FP30 Standard
FP30 Standard 082	FP30 Standard
FP30 Standard 083	FP30 Standard
FP30 Standard 084	FP30 Standard
FP30 Standard 085	FP30 Standard
FP30 Standard 086	FP30 Standard
FP30 Standard 087	FP30 Standard
FP30 Standard 088	FP30 Standard
FP30 Standard 089	FP30 Standard
FP30 Standard 090	FP30 Standard
FP30 Standard 091	FP30 Standard
FP30 Standard 092	FP30 Standard
FP30 Standard 093	FP30 Standard
FP30 Standard 094	FP30 Standard
FP30 Standard 095	FP30 Standard
FP30 Standard 096	FP30 Standard
FP30 Standard 097	FP30 Standard
FP30 Standard 098	FP30 Standard
FP30 Standard 099	FP30 Standard
FP30 Standard 100	FP30 Standard

SPANWALL

CARRYDUFF BUSINESS PARK, COMBER ROAD, CARRYDUFF, BELFAST, BT8 8AN.
 TEL : +44(0)28 9081 5303 FAX : +44(0)28 9081 5449
 E-MAIL : Info@spanwall.com
 WEBSITE : www.spanwall.com

TITLE : Cladding Zone Variations	
DRAWING No. : Standard Details	DRAWN BY : Andrew Creane
PART No. : FP30-008a	DATE : 21/04/2023
SCALE : NTS	
APPROVED BY : JR	
© COPYRIGHT OF THE DESIGNERS. DR DESIGN RIGHTS	

DATE:	ISSUE:	CHANGE:
12/10/2023	Rev A	

* - Maximum panel position to inside
 ** - Maximum panel position to outside
 SPP - Standard panel position

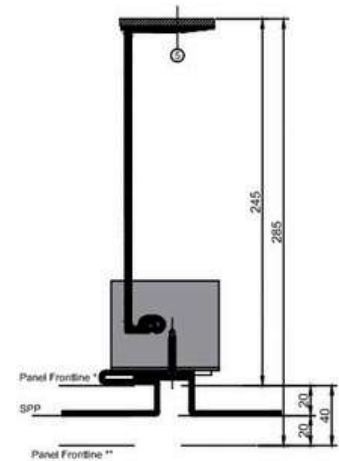
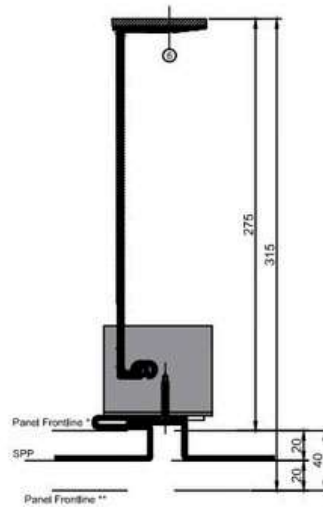
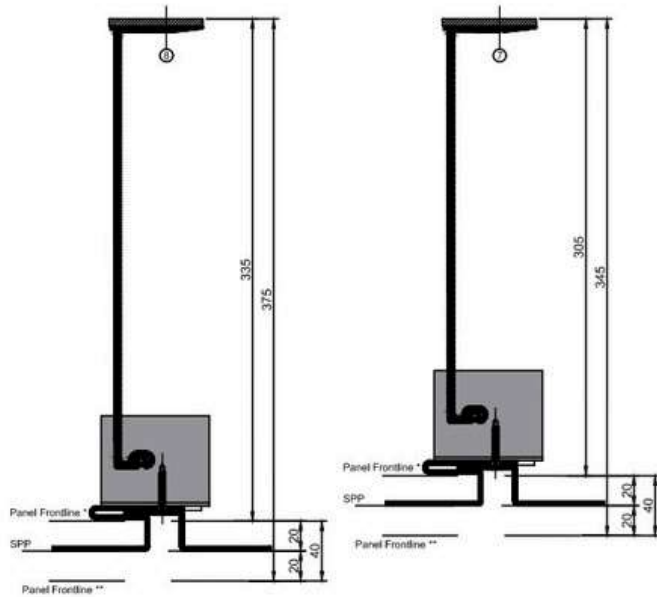
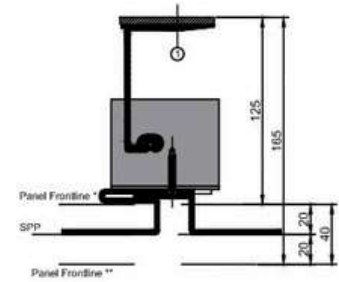
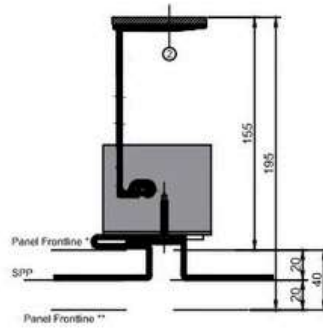
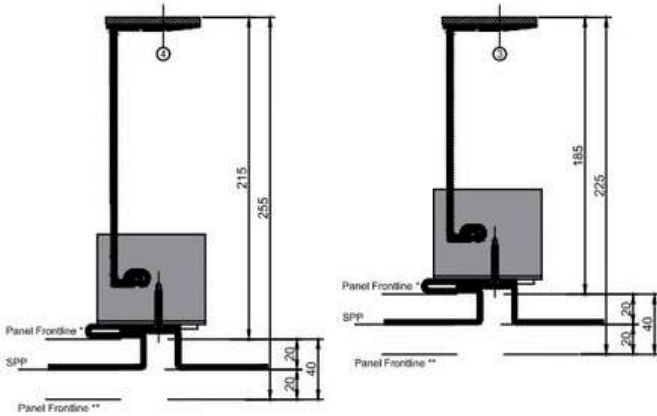
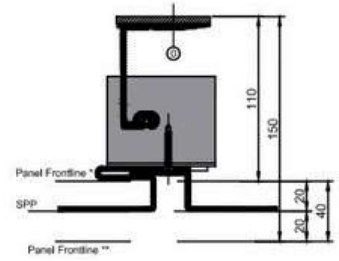

Item	Description	Cladding Zone Range
0	Wall Bracket 25	110 - 150mm
1	Wall Bracket 90	125 - 165mm
2	Wall Bracket 120	155 - 195mm
3	Wall Bracket 150	185 - 225mm
4	Wall Bracket 180	215 - 255mm
5	Wall Bracket 210	245 - 285mm
6	Wall Bracket 240	275 - 315mm
7	Wall Bracket 270	305 - 345mm
8	Wall Bracket 300	335 - 375mm

SPANWALL

CARRYDUFF BUSINESS PARK, COMBER ROAD, CARRYDUFF, BELFAST, BT8 8AN.
 TEL : +44(0)28 9081 5303 FAX : +44(0)28 9081 5449
 E-MAIL : Info@spanwall.com
 WEBSITE : www.spanwall.com

TITLE :

Cladding Zone Variations

DRAWING No. :
Standard Details

DRAWN BY :
Andrew Creane

SCALE :
NTS

PART No. :
FP30-008b

DATE :
21/04/2023

APPROVED BY :
JR

© COPYRIGHT OF THE DESIGNERS.

DR DESIGN RIGHTS



Talk to us today...

Main Office

**Unit 1, Carryduff Park, Comber Road,
Carryduff, Belfast BT8 8AN Northern Ireland**

T: +44 (0)28 9081 5303

E: info@spanwall.com

Head of Commercial - Gabe McArdle

T: +44 (0)79 6655 2116

E: gmcardle@spanwall.com

Business Development Manager GB North - Rinoj Raju

T: +44 (0)78 4241 4938

E: rāju@spanwall.com

www.spanwall.com

